

**INTERNATIONAL**

**J/70**

**CLASS RULES**



Effective Date: 3 January 2013

| Updates from prior version indicated by left column hash mark.

# INTRODUCTION

---

**These Class Rules have been assembled with the collective input of several class administrators, sailmakers, J builders, J dealers, ISAF staff members and J/70 owners. Prior to the Class being formed with suitable By-Laws in place and with at least 200 members, J Boats Inc. (J/70 copyright and trademark holder) shall take the position of the Class Association. Please contact [info@jboats.com](mailto:info@jboats.com) with any inquiries.**

*This introduction only provides an informal background and the **International** J/70 Class Rules proper begin on the next page.*

*The J/70 Class has been created as a strict one-design Class where the true test when racing is between crews and not boats and equipment. The fundamental objective of these class rules is to ensure that this concept is maintained.*

*J/70 hulls, hull appendages and rigs shall be manufacturer controlled and shall only be produced by a manufacturer licensed by J Boats, Inc. Equipment is built in accordance with the J/70 Building Specification and Configuration Manual. These parts having left the manufacturer may only be altered to the extent permitted in Section C of the class rules.*

*J/70 sails are measurement controlled to control all the primary dimensions but may be made by any manufacturer. In order to confirm compliance with the class rules sails are required to be **certified** by an **official measurer** or by a manufacturer licensed under the ISAF In House Certification. These parts may only be altered to the extent permitted in Section C of the class rules after **certification control** has been performed.*

*Rules regulating the use of equipment during a race are contained in Section C of these class rules, in ERS Part I and in the Racing Rules of Sailing.*

**THESE RULES ARE CLOSED CLASS RULES WHERE IF IT DOES NOT SPECIFICALLY SAY THAT YOU “MAY” THEN YOU “SHALL NOT.”**

**COMPONENTS, AND THEIR USE, ARE DEFINED BY THEIR DESCRIPTION.**

# PART I – ADMINISTRATION

---

## Section A – General

The J/70 Class Association has been created as a strict one-design class where the true test when racing is between crews and not boats. The fundamental objective of the **class rules** is to ensure that this concept is maintained, while preserving the J/70's ease of handling, low cost of ownership, safety and comfort.

### A.1 LANGUAGE

- A.1.1 The official language of the class is English and in case of dispute over translation the English text shall prevail.
- A.1.2 The word “shall” is mandatory and the word “may” is permissive.
- A.1.3 Except where used in headings, when a term is printed in “**bold**” the definition in the ERS applies and when a term is printed in “*italics*” the definition in the RRS applies.
- A1.4. **Section in Blue Text are only relevant once the class gains ISAF Status**

### A.2 ABBREVIATIONS

- A.2.1 ISAF International Sailing Federation
- MNA ISAF Member National Authority
- ICA International J/70 Class Association
- NCA J/70 National Class Association
- ERS Equipment Rules of Sailing
- RRS Racing Rules of Sailing
- OSR Offshore Special Regulations ([www.sailing.org/specialregs](http://www.sailing.org/specialregs))
- LM Licensed Manufacturer by J/Boats, Inc.

### A.3 AUTHORITIES

- A.3.1 **The international authority of the class is ISAF which shall co-operate with the ICA and certification authority in all matters concerning these class rules.**
- A.3.2 Notwithstanding anything contained herein, the LM and J/Boats has the authority to withdraw the manufacturer declaration and therefore the right to compete and shall do so on the request of the ISAF.
- A.3.2 Notwithstanding anything contained herein, the **certification authority** has the authority to withdraw a **certification** of the sails and shall do so on the request of the ISAF.
- A.3.3 Neither the **certification authority** nor an **official measurer**, an **international measurer** or an **equipment inspector** is under any legal responsibility in respect of these **class rules** or the accuracy of measurement. No claim arising from them shall be entertained.

#### **A.4 ADMINISTRATION OF THE CLASS**

- A.4.1 ISAF has delegated its administrative functions of the class excluding sails to the ICA.
- A.4.2 ISAF has delegated its administrative functions of the class in regard to sails to MNAs. The MNA may delegate part or all of its functions, as stated in these **class rules**, to an NCA.
- A.4.3 In countries where there is no MNA, or the MNA does not wish to administrate the class, its administrative functions as stated in these **class rules** shall be carried out by the ICA which may delegate the administration to an NCA.

#### **A.5 CLASS RULES CHANGES**

- A.5.1 Amendments to these **class rules** shall be proposed inline with the constitution and are subject to the approval of J/Boats.
- A.5.1 Amendments to these **class rules** shall be proposed inline with the constitution and are subject to the approval of the ISAF in accordance with the ISAF Regulations.
- A.5.2 Amendments to the configuration manual shall be proposed inline with the constitution and are subject to the approval of J/Boats and ISAF in accordance with the ISAF Regulations.
- A.5.3 Amendments to the construction manual are subject to the approval of J/Boats and the ISAF Secretariat Technical Department.

#### **A.6 RULES CHANGES AT EVENTS**

- A.6.1 At all events ISAF Regulation 10.5(f) applies.

#### **A.7 RULES INTERPRETATION**

- A.7.1 Interpretation of ERS shall be made in accordance with the ISAF Regulations.
- A.7.2. Interpretation of **class rules** shall be made by the Class Executive Committee.
- A.7.2 Interpretation of **class rules** shall be made in accordance with the ISAF Regulations.]
- A.7.3. Interpretation of the configuration manual shall be made by the Class Executive Committee and J/Boats in consultation with the ISAF.
- A.7.4. Interpretation of construction manual shall be made by J/Boats in consultation with ISAF.

#### **A.8 INTERNATIONAL CLASS FEE AND ISAF BUILDING PLAQUE**

- A.8.1 ISAF shall, after having received the International Class Fee for the hull, send the ISAF Building Plaque and a measurement form to the licensed hull builder.]

#### **A.9 SAIL NUMBERS**

- A.9.1 Sail numbers shall correspond to the hull number molded into the transom of each boat.

#### **A.10 BOAT (EX SAILS) MANUFACTURER DECLARATION**

- A.10.1 A Manufacturer's declaration shall record the following information:
  - (a) Class

- (b) Quality Control Manufacturer Statement
- (c) Hull identification number
- (d) Hull appendage identification number
- (d) Builder/Manufacturers details
- (e) Date of issue of initial manufacturer's declaration
- (f) Section D & E - Modification, Maintenance and Repair details
- (g) **Hull** weight.

## **A.11 VALIDITY OF MANUFACTURER DECLARATION**

A.11.1 A manufacturer declaration becomes invalid upon:

- (a) the change to any items recorded on the declaration as required
- (b) withdrawal by the ISAF or LM
- (c) the issue of a new manufacturer declaration

## **A.12 RE-ISSUE OF MANUFACTURER DECLARATION**

A.12.1 The **LM** may re-issue a Manufacturer Declaration to a **hull**, if the **hull** conforms to the **class rules**..

- (a) when it is invalidated under A.11.1(a) or (b).
- (b) when it is invalidated under A.10.1(f) at its discretion and any remedial work shall be recorded on the re-issued declaration
- (c) in case of loss
- (d) at the request of ISAF

## **A.13 RETENTION OF DOCUMENTATION**

A.13.1 The **skipper** shall retain the currently issued manufacturer declaration.

A.13.2 A copy of the manufacturer declaration shall be retained by the LM and a copy shall be sent to the ICA.

## Section B – Boat Eligibility and Equipment Inspection

For a **boat** to be eligible for *racing*, it shall comply with the rules in this section.

### B.1 CLASS RULES AND CERTIFICATION

B.1.1 The **boat** shall:

- (a) be in compliance with the **class rules**.
- (b) have a valid manufacturer's declaration.
- (c) have valid **certification marks** on all sails used for class racing.

### B.2 CLASS ASSOCIATION MARKINGS

B.2.1 A valid Class Association Membership Sticker, if required by the NCA or the ICA, shall be affixed to the hull in a conspicuous position.

B.2.2 Sails shall carry a Class Association Sail Royalty Label.

### B.3 EQUIPMENT INSPECTION

B.3.1 In the case of a dispute at an event alleging non-compliance with **class rules** and building specification and construction manual where specific measurements are not stated, the Event **Equipment Inspector** shall adopt the following procedure:

- a) A sample measurement of the disputed item shall be obtained by taking the identical measurement from a randomly selected group of boats or items of equipment (control group).
- b) The measurement of the disputed boat or items of its equipment, taken using the same technique as above, shall be compared to the sample.
- c) If any of the measurements obtained from the disputed boat or item of equipment lie outside the corresponding range of measurements found in the control group, the matter together with the details of the measurement methods and any other relevant information shall be referred to the Race Committee.

### B.4 EVENT LIMITATION MARKS

B.4.1 If an event uses **event limitation marks** these marks shall not be removed during the event. If the **event limitation mark** becomes damaged or lost this shall be reported to the race committee as soon as possible.

# PART II – REQUIREMENTS AND LIMITATIONS

---

The **crew** and the **boat** shall comply with the rules in Part II when *racing*. In case of conflict Section C shall prevail.

The rules in Part II are **closed class rules**.

## Section C – Conditions for Racing

### C.1 GENERAL

#### C.1.1 RULES

- (a) The ERS Part I – Use of Equipment shall apply.
- (b) RRS 42.3(c) is modified to allow the gennaker sheet to be played without restriction.

### C.2 ADVERTISING

#### C.2.1 LIMITATIONS

Advertising shall only be displayed in accordance with the ISAF Advertising Code. (See ISAF Regulation 20)

### C.3 CREW

#### C.3.1 LIMITATIONS ON THE CREW

- (a) The **crew** shall consist of 3 or 4 persons.
- (b) No **crew** member shall be substituted during the world championship and any event of 6 or less consecutive days, without the approval of the race committee or Jury.

#### C.3.2 LIMITATIONS ON THE DRIVER

The Driver shall be a current class member in good standing, and meet the following criteria except in the event of an emergency involving the safety of the boat or crew where the boat may be steered by any crew member. Any such incident shall be reported to the protest committee which may penalize the boat. The penalty may be less than disqualification.

##### (a) Permitted Drivers:

- (i) Owner - a **crew** who legally owns and pays 50% of the yacht and the running costs.
  - (ii) **Crew** Member - a Group 1 Competitor per the ISAF Sailor Classification Code Regulation 22. All non-owner Group 1 Drivers shall hold valid classifications. (Competitors requiring a classification should apply on the ISAF website [www.sailing.org/classification](http://www.sailing.org/classification)).
  - (iii) Charterer - an Owner or Group 1 Charterer confirmed by the Owner of the boat for that event.
- (b) For events of six or less consecutive days, not more than two Drivers can be designated, at least one of which must be an Owner. From five minutes before the start until the finish, the boat shall be helmed by the designated

Driver(s) except for momentary absences for personal or shipboard needs not to exceed five (5) minutes when a Group 1 **crew** member may drive.

- (c) The class executive committee shall be the sole interpreter of who qualifies as an Owner.

### C.3.3 USE

#### (A) CREW POSITIONING

- (i) Except for momentary sail handling and/or repair needs, **crew** shall remain aft of the mast while on deck.
- (ii) **Crew** shall not stand and lean out over the cockpit safety lines or stern rails to promote roll tacking, roll gybing or to increase hiking leverage.
- (iii) While seated on deck, **crew** shall have the base of their spine on the deck and inboard of the cockpit safety lines at all times.
- (iv) Not more than two **crew** may have their legs outboard of the sheerline.
- (v) When tacking or gybing, **crew** shall not hang, push or pull on the shrouds, mast, cockpit safety lines, stanchions or any other item to promote the maneuver.

## C.4 PERSONAL EQUIPMENT

### C.4.1 MANDATORY

- (a) The boat shall be equipped with a **personal flotation device** for each **crew** member to the minimum standard EN 393, ISO 124020-5 (Level 50), or USCG Type III.

## C.5 PORTABLE EQUIPMENT

### C.5.1 GENERAL

- (a) Mandatory equipment shall be functional for its intended use.

### C.5.2 FOR USE

#### (a) MANDATORY

- (1) One anchor and chain combined not less than 5kg in weight with at least 40m of rode with minimum diameter of 8mm.
- (2) One bucket of not less than 9 liter capacity
- (3) One manual bilge pump
- (4) One marine first aid kit
- (5) One main companionway hatch
- (6) One main companionway dropboard
- (7) One operational VHF radio
- (8) One throwable flotation device

#### (b) OPTIONAL

- (1) Electronic or mechanical timing devices
- (2) Navigation lights
- (3) Tactical and navigational charts and instruments, excluding masthead electronic wind instruments.



- (4) Power source for optional electronics.
- (5) Mooring lines, fenders, spare lines, spare equipment, tool kit, and other personal items that provide no sailing performance advantage.
- (6) V-berth cushions.

C.5.3 NOT FOR USE

(a) MANDATORY

- (1) One functioning outboard engine with a minimum weight of 12kg (empty of fuel). If a petrol engine, then **boat** shall carry a fire extinguisher that meets local regulations.

**C.6 BOAT**

C.6.1 WEIGHT

	minimum
The weight of the <b>boat</b> in dry condition	812 kg

The weight shall be taken excluding **sails** and all portable equipment as listed in #C.5 except that the companionway hatch, the dropboard and the outboard engine (#C.5.3) shall be included.

- C.6.2 When the **boat** weight is less than the minimum requirement, **corrector weights** of metal with minimum density of 7.0 g/cm<sup>3</sup> (i.e. iron, lead) shall be permanently fastened in accordance with Appendix H-2.

**C.7 HULL**

C.7.1 MODIFICATIONS, MAINTENANCE AND REPAIR

- (a) Below the waterline, the gelcoat may be lightly abraded to allow for the application of anti-foul paint, for boats that are to be primarily wet-sailed in their home waters. The abrasion of gelcoat shall be the minimum needed to ensure the adhesion of the paint and shall not involve fairing of any sort. If an epoxy barrier coat is applied, then anti-foul paint shall also be applied.
- (b) Routine maintenance of the **hull**, such as polishing is permitted, provided the intent and effect is to polish only.
- (c) The **hull** topside gelcoat surface shall not be removed except for light sanding prior to topside painting.
- (d) Holes may be made and local reinforcement in the **hull** for the fitting of electronic navigation systems.
- (e) Gelcoat scratches and minimal damaged areas may be repaired.

C.7.2 FITTINGS

- (a) The cockpit safety lines shall not deflect more than 25mm from a straight line between two points of support when a force of 4kg is applied at the point of maximum deflection. Pads may be added to the safety lines.

- (b) The rear gate line across the transom shall be closed while racing, and not deflect more than 75mm when a force of 4kg is applied at the point of maximum deflection.
- (c) Placement of line bags and winch handle holders in the cockpit.
- (d) Lashing, tape and other anti-chafe gear on **hull, rig or sails**.
- (e) Height and angle of mainsheet cleat riser and wedge may be modified.
- (f) Substitution of a 6" mooring cleat for the bow "U" bolt.
- (g) Addition of one cam cleat (size Harken 150 or equivalent) within 50mm of each side-deck mounted jib sheet cleat for the purpose of cleating the jib sheet to windward.
- (h) Nonslip material on deck to promote safe movement.
- (i) Installation of a belowdecks spinnaker bag of optional design through the main companionway or foredeck hatch.
- (j) Replacement of the following items is permitted provided that the replacement part is of similar size, weight, power ratio and performs the same function.
  - (1) Blocks, cleats, mainsheet swivel base.
  - (2) Shackles, pins, open body turnbuckles.
  - (3) Inspection hatches.
- (k) Five ratcheting type blocks are permitted - two for the headsail cheek blocks, two for gennaker blocks, and one for the mainsheet base block.

## **C.8 HULL APPENDAGES**

### **C.8.1 MODIFICATIONS, MAINTENANCE AND REPAIR**

The following is permitted without the approval of the LM.

- (a) The **hull appendages** may be lightly sanded for the purpose of applying anti-foul paint. If an epoxy barrier coat is applied, then anti-foul shall also be applied.
- (b) Routine maintenance of the **hull appendages**, such as polishing, is permitted provided the intent and effect is to polish only.
- (c) Gelcoat scratches and minimal damaged areas may be repaired.
- (d) Modification of the keel wedges is prohibited.
- (e) The tiller extension may be replaced with a similar functioning item provided the length does not exceed 1120mm.

### **C.8.2 KEEL**

- (a) USE
  - (1) The **keel** shall be fixed in the down position using the standard stainless strap.

### **C.8.3 RUDDER**

- (a) USE
  - (1) The **rudder** shall be fixed to the transom using the builder-supplied rudder hardware and pins.

## C.9 RIG

### C.9.1 MODIFICATIONS, MAINTENANCE AND REPAIR

The following is permitted without the approval of the LM. Unless stated otherwise, items mentioned in this section may be obtained by any manufacturer or supplier.

- (a) Routine maintenance such as cleaning, polishing, and repair of minor abrasions.
- (b) A protective pad surrounding the mast under the gooseneck.
- (c) Telltales, Windex and other non-electronic wind indicators.
- (d) Running rigging may be replaced by line of any type but shall meet the minimum dimensions stated in #F.4.1.
- (e) Use of elastic chord to take up slack on the backstay bridle.
- (f) An anti-chafe protective sleeve over the boomvang system.
- (g) A batten not to exceed 150mm added to the end of the **bowsprit** as a preventer for the gennaker sheet.
- (h) Tape or other materials added around the bowsprit to minimize water intrusion.
- (i) A **boom** topping lift rigged to either the mast crane or the upper backstay leg.
- (j) A fiberglass backstay flicker may be mounted on the mast.
- (k) A fixed spanner may be attached between the upper and lower shroud pins above the turnbuckles to facilitate tuning the rig.

### C.9.1 MAST

- (a) DIMENSIONS
- (b) USE

- (1) The mast as supplied and assembled shall be stepped in accordance with the rigging instructions.

### C.9.2 BOOM

- (a) DIMENSIONS

	minimum	maximum
<b>Limit mark width</b>	20mm	
<b>Outer point distance</b>		2876mm

- (b) USE

- (1) The intersection of the aft edge of the mast **spar** and the top of the boom **spar**, each extended as necessary, shall not be below the upper edge of the mast **lower limit mark** when the boom **spar** is at 90° to the mast **spar**.

### C.9.3 BOWSPRIT

#### (a) DIMENSIONS

	minimum	maximum
<b>Hull to bowsprit outer point</b>		1495mm

#### (b) USE

- (1) The bowsprit shall be fully retracted at all times except when the gennaker is being set, is set, or is being retrieved, and shall be retracted at the first reasonable opportunity after the retrieval.
- (2) An extended bowsprit shall not be considered part of the boat for the purposes of 1) establishing an overlap, or 2) establishing right of way, unless the gennaker is set.

### C.9.4 STANDING RIGGING

#### (b) USE

- (1) The forestay and shrouds shall not be adjusted whilst racing (backstay adjustment is permitted).
- (2) The forestay shall not be adjusted from the time the boat leaves its dock or mooring each day until the boat has finished racing for the day.

### C.9.5 RUNNING RIGGING

#### (a) USE

- (1) Mainsheet purchase of a minimum of 4:1 and maximum of 6:1.
- (2) Traveler purchase not to exceed 3:1.
- (3) Boomvang purchase not to exceed 8:1.
- (4) Headsail sheet purchase of either 1:1 or 2:1.
- (5) Outhaul purchase not to exceed 4:1 inside the **boom**, but the tail maybe led through the mainsail clew and dead-ended to the end of the **boom** to achieve 8:1.
- (6) No lines shall lead below deck except for the furler line, the bowsprit line and an optional gennaker retrieval line.
- (7) The gennaker sheets shall be led through the standard block locations.
- (8) Cunningham purchase not to exceed 6:1.

## C.10 SAILS

### C.10.1 MODIFICATIONS, MAINTENANCE AND REPAIR

- (a) Routine maintenance, minor repairs and the addition of draft stripes and telltales is permitted.
- (b) **Sails** may not be **recertified** during an event without the permission of the race committee.
- (c) If a **sail** has been lost or damaged it may be repaired or replaced only with the approval of the race committee or jury.

- (d) Battens may be used in **batten pockets**, in which case they shall be of fiberglass.

#### C.10.2 LIMITATIONS

- (a) Not more than 1 mainsail, 1 headsail, and 1 gennaker shall be carried aboard.
- (b) Not more than 1 mainsail, 1 headsail, and 1 gennaker shall be presented for **event** measurement and used during an event of 6 or less consecutive days except when a **sail** has been lost or damaged beyond repair.

#### C.10.3 MAINSAIL

##### (a) IDENTIFICATION

The national letters and sail numbers shall comply with the RRS except where prescribed otherwise in these **class rules**.

##### (b) USE

- (1) The **sail** shall be hoisted on a **halyard**.
- (2) The highest visible point of the **sail**, projected at 90° to the mast **spar**, shall not be set above the lower edge of the mast **upper limit mark**. The intersection of the **leech** and the top of the boom **spar**, each extended as necessary, shall not be behind the fore side of the boom **outer limit mark**.
- (3) The **Luff** shall be in the **spar** groove or attached to a mainsail luff slide system.
- (4) The **tack** of the mainsail may float.
- (5) The **clew** shall be attached to the outhaul and down to the boom.

#### C.10.4 HEADSAIL

##### (a) USE

- (1) The **headsail** shall be attached to the roller furling system and be capable of being furled.
- (2) The **headsail** shall remain hoisted while racing, except when in the process of being repaired.

#### C.10.5 GENNAKER

##### (a) IDENTIFICATION

Sail identification is not required on the gennaker.

##### (b) USE

- (1) A spinnaker retrieval line may be attached to the sail.

## Section D – Hull

### D.1. PARTS

- (a) Hull shell
- (b) Deck
- (c) Internal mouldings and bulkheads
- (d) Fixed seats (2) below deck

- (e) Mast compression post
- (f) Cockpit keel cover and companionway hatch

## **D.2 GENERAL**

### **D.2.1 RULES**

- (a) The **hull** shall comply with the **class rules** in force at the time of manufacture.

### **D.2.2 DEFINITIONS**

- (a) HULL DATUM POINT

The **hull datum point** is the intersection, on the centerplane of the hull, between the underside of the shell and the transom, each plane extended as necessary.

### **D.2.3 IDENTIFICATION**

- (a) Moulded-in hull identification number assigned by J/Boats, Inc.
- (b) Hull number shall be as per the ISAF Plaque at the aft end of the cockpit starting with hull number #TBA.

### **D.2.4 BUILDERS**

- (a) The **hull** shall be built by a builder licensed by J/Boats, Inc.
- (b) All moulds shall be approved by J/Boats, Inc. and ISAF.

### **D.2.5 MODIFICATIONS, MAINTENANCE AND REPAIR**

The following may be done by a LM, or by anybody after a formal request has been made to the LM and written approval is received by the owner. This shall require the manufacturer's declaration to be re-issued stating the work done.

- (a) If any **hull** is damaged and requires to be repaired in any other way than described in section C.

## **Section E – Hull Appendages**

### **E.1 PARTS**

#### **E.1.1 MANDATORY**

- (a) **Keel**
- (b) **Rudder**

#### **E.1.2 OPTIONAL**

- (a) Builder supplied or approved **keel** weed cutter

## **E.2 GENERAL**

### **E.2.1 RULES**

- (a) **Hull appendages** shall comply with the **class rules** in force at the time of **manufacturer** except those rules in Section C where the current rules take precedence.

### **E.2.2 MODIFICATIONS, MAINTENANCE AND REPAIR**

The following alterations may be made by a LM, or by anybody after a formal request has been made to the LM and written approval is received by the owner. This shall require the manufacturer's declaration to be re-issued

- (a) If any **hull appendage** is damaged and requires to be repaired in any other way than described in section C the details shall be recorded on the Manufacturer's declaration.
- (b) The optional weed cutter slot in the **keel** shall not be filled or covered unless the blade assembly is removed.

### **E.2.3 MANUFACTURERS**

- (a) The **hull appendages** and molded tiller shall be made by manufacturers licensed by J/Boats Inc.

## **Section F – Rig**

### **F.1 PARTS**

#### **F.1.1 MANDATORY**

- (a) **Mast**
- (b) **Boom**
- (c) Standing **rigging**
- (d) Running **rigging**
- (e) **Bowsprit**

### **F.2 GENERAL**

#### **F.2.1 MANUFACTURER**

- (a) Spars shall only be supplied by a licenced manufacturer and built in accordance with the manufacturing specification.
- (b) The manufacturer of the standing and running rigging is optional.

#### **F.2.2 RULES**

- (a) The **spars** and their fittings shall comply with the **class rules** in force at the time of manufacture of the **spar** except those rules in Section C where the current rules take precedence.
- (b) The standing and running **rigging** shall comply with the **class rules**.

### F.2.3 MODIFICATIONS, MAINTENANCE AND REPAIR

The following alterations may be made by a LM, or by anybody after a formal request has been made to the LM and written approval is received by the owner. This shall require the manufacturer's declaration to be re-issued.

- (a) If any **spar** is damaged and requires repair in any other way than described in section C the details shall be recorded on the Manufacturer's declaration.

### F.3 STANDING RIGGING

#### F.3.1 MATERIALS

- (a) The forestay, upper shrouds and lower shrouds shall be 5mm 1x19 stainless wire with an open body turnbuckle at the bottom end.
- (b) The upper and lower backstay shall be at least 5mm diameter of low-stretch composite rope (such as Dyneema).

### F.4 RUNNING RIGGING

#### F.4.1 DIMENSIONS (Minimum line diameter for entire length of line)

	Minimum Diameter (mm)	Recommended Length (m)
Main Halyard	6mm	
Mainsheet	8mm	
Mainsheet Strop	5mm	
Traveler	5mm	
Vang	6mm	
Vang Strop	5mm	
Headsail Halyard	4mm	
Headsail Halyard Fine-tune	6mm	
Headsail Sheet	8mm	
Gennaker Halyard	6mm	
Gennaker Sheet (excluding connector strop to gennaker clew)	6mm	
Sprit Outhaul	6mm	
Tackline	7mm	
Backstay Control	6mm	

## Section G – Sails

### G.1 PARTS

#### G.1.1 MANDATORY

- (a) Mainsail
- (b) Headsail
- (c) Gennaker



## G.2 GENERAL

### G.2.1 RULES

(a) **Sails** shall comply with the **class rules** in force at the time of **certification**.

### G.2.2 CERTIFICATION

(a) The **official measurer** or **In-House Official Measurer** shall **certify** mainsails and headsails in the **tack** and spinnakers in the **head** and shall sign and date the **certification mark**.

(b) The ISAF or an MNA may appoint one or more **In-House Official Measurers** to measure and **certify sails** produced by that manufacturer..

### G.2.3 SAILMAKER

(a) No licence is required.

(b) For spinnakers the weight in  $g/m^2$  and the material name of the **body of the sail** shall be indelibly marked near the **head point** by the sailmaker together with the date and his signature or stamp.

### G.2.4 J/70 CLASS SAIL ROYALTY LABEL

Each **sail** shall have permanently fixed (with stitching) in its tack, a numbered class royalty label. Labels are available from the Class (info@jboats.com). The label shall not be transferred from one sail to another.

### G.2.5 MODIFICATIONS, MAINTENANCE AND REPAIR

If any **sail** is damaged and requires repair in any other way than described in section C, the **sail** will require re-**certification** which may require **fundamental measurement**.

## G.3 MAINSAIL

### G.3.1 IDENTIFICATION

(a) The class insignia available from J/Boats shall conform with the dimensions in Appendix H-1.

### G.3.2 MATERIALS

(a) The **ply** fibres shall consist of **woven ply** of polyethylene terephthalate (PET).

(b) **Sail reinforcement** shall consist of polyethylene terephthalate (PET).

(c) Battens of fiberglass.

### G.3.3 CONSTRUCTION

(a) The construction shall be: **soft sail; single ply sail**.

(b) The **body of the sail** shall be constructed of **woven ply** throughout.

(c) The mainsail shall have five **batten pockets** in the **leech**. The top three **batten pockets** shall be full length extending from luff to leech.

(d) The following are permitted: Stitching, glues, tapes, bolt ropes, corner eyes, headboard with fixings, Cunningham eye or pulley, **batten pocket patches**, **batten pocket** elastic, **batten pocket** end caps, mast slides, adjustable foot and leech lines, **windows**, tell tales, sail shape indicator stripes and items as permitted or prescribed by other applicable *rules*.

(e) Reef points are optional.

- (f) **Windows** are permitted below the **half width**.
- (g) The **leech** shall not extend aft of straight lines between:
  - (1) the **aft head point** and the intersection of the **leech** and the upper edge of the nearest **batten pocket**,
  - (2) the intersection of the **leech** and the lower edge of a **batten pocket** and the intersection of the **leech** and the upper edge of an adjacent **batten pocket** below,
  - (3) the **clew point** and the intersection of the **leech** and the lower edge of the nearest **batten pocket**.

#### G.3.4 DIMENSIONS

<b>Mainsail</b>	Minimum	Maximum
Sail cloth weight - woven ply (PET-Dacron)	235g/m2	
<b>Leech length</b>		8335mm
<b>Luff length</b>		7974mm
<b>Foot length</b>		2876mm
<b>Top width</b>		364mm
<b>Upper width</b> (where the <b>upper leech point</b> is defined as the point on the <b>leech</b> equidistant from the <b>head point</b> and the <b>three quarter leech point</b> .)		880mm
<b>Three-quarter width</b>		1425mm
<b>Half width</b>		2134mm
<b>Quarter width</b>		2570mm
<b>Window area</b> (combined area of all <b>windows</b> )		1.0 m2
Gaff batten (#1) located inside radius from <b>head point</b>		390mm
Center of #2 <b>batten pocket</b> at leech from <b>head point</b>	1255mm	1305mm
Center of #3 <b>batten pocket</b> at leech from <b>head point</b>	2475mm	2525mm
Inside <b>batten pocket</b> length - battens #4 and #5		1280mm

#### G.4 HEADSAIL

##### G.4.1 MATERIALS

- (a) The **ply** fibres shall consist of **woven ply** of polyethylene terephthalate (PET).
- (b) **Sail reinforcement** shall consist of polyethylene terephthalate (PET).
- (c) Battens of fiberglass.
- (d) **Windows** may only be located below the **half width**.

##### G.4.2 CONSTRUCTION

- (a) The construction shall be: **soft sail; single ply sail**.
- (b) The headsail shall have no more than 3 **batten pockets** in the **leech**. When fitted, the battens shall not prevent the headsail from furling completely.
- (c) The following are permitted: Stitching, glues, tapes, corner eyes, batten pocket elastic, **batten pocket patches**, **batten pocket** end caps, adjustable

leech and foot lines, **windows**, tell tales, sail shape indicator stripes, UV protective may be applied to the leech and foot to cover the sail when furled; and items as permitted or prescribed by other applicable *rules*.

- (d) The headsail may be fitted with hanks, or a zip luff that encloses the forestay.
- (e) The headsail clew may be fitted with up to two headsail sheet blocks having a sheave diameter not larger than 40mm.

#### G.4.3 DIMENSIONS

<b>Headsail</b>	Minimum	Maximum
Sail cloth weight - woven ply (PET-Dacron)	235g/m <sup>2</sup>	
Reinforcements - (PET-Dacron)		
<b>Luff Length</b>		8000mm
<b>Luff Perpendicular</b>		2450mm
<b>Top width</b>		64mm
<b>Three-quarter width</b>		650mm
<b>Half width</b>		1250mm
<b>Quarter width</b>		1860mm
<b>Window area</b> (combined area of all <b>windows</b> )		.75 m <sup>2</sup>
<b>Batten pockets</b> - 3 max which divide leech equally +/- 25mm		
Inside <b>batten pocket</b> length		950mm

### G.5 GENNAKER

#### G.5.1 MATERIALS

- (a) The **ply** of the **body of the sail** shall be manufactured from woven nylon.

#### G.5.2 CONSTRUCTION

- (a) The construction shall be: **soft sail, single ply sail**.
- (b) The **body of the sail** shall consist of the same **woven ply** throughout.
- (c) The following shall be fitted: Adjustable leech and luff lines.
- (d) The following are permitted: Stitching, glues, tapes, corner eyes, recovery line eyes, tell tales and items as permitted or prescribed by other applicable *rules*.

#### G.5.3 DIMENSIONS

<b>Spinnaker</b>	Minimum	Maximum
Material - nylon	40g/m <sup>2</sup>	
<b>Luff length</b>		10800mm
<b>Leech length</b>		8800mm
<b>Foot length</b>		5700mm
<b>Half width</b>		5560mm

## Section H - Appendices

### H.1 SAIL INSIGNIA

The J/70 Class insignia shall be in dark blue with overall dimensions of 610 x 320mm and shall be affixed on both sides of the J/70 Class mainsail with the bars nearly perpendicular to a line between the head and center of the boom and between the upper two batten pockets. A J/70 world champion may elect to display the J/70 Class insignia in gold. A J/70 continental champion may elect to display the J/70 Class insignia in silver. A J/70 NCA champion may elect to display the J/70 Class insignia in bronze.



### H.2 CORRECTOR WEIGHT LOCATION

Corrector weight shall be fixed in place as shown with 2/3rds of the weight in forward location and 1/3 of the weight in aft location.

J/70 Class Corrector Weight Locations

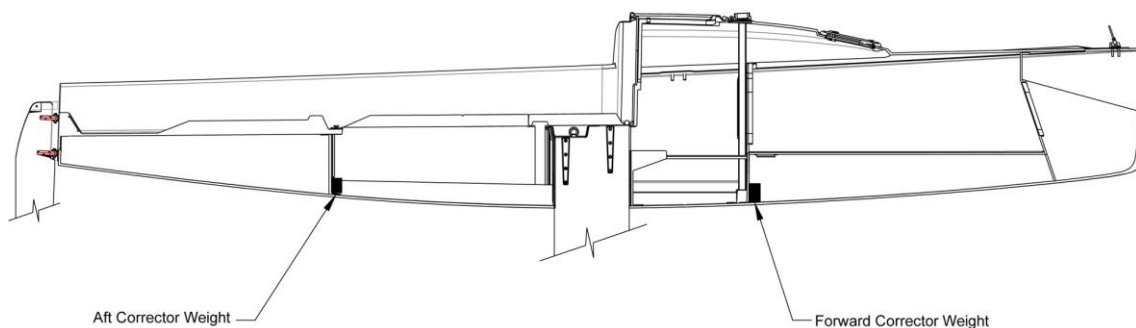

# PART III – EVENT RULES

---

These rules must be invoked individually by the notice of race or sailing instructions. The default is these rules do not apply. The notice of race shall state that “J/70 Class Rules \_\_\_\_\_ of Section I are invoked.”

## Section I

### I.1 SPARE GENNAKER

One spare class gennaker (that meets the requirements of C.10, G.2 and G.5) may be presented for measurement and registration for an event, and carried aboard, but shall not be used during an event except when the primary gennaker has been lost or damaged to the point where it cannot be effectively repaired while afloat.

### I.2 LEGS-IN CREW POSITIONING (option for team-racing, match-racing, frostbiting, and provided-boat events).

Class rule #C.3.3(iv) is replaced with the following: **crew** shall have their legs inboard of the sheerline.

### I.3 SUPPORT BOATS

Individual support or coach boats shall not have contact of any nature, including:

- (i) communication by radio, telephone, internet, vocal signal, visual signalling of any kind (i.e., tactical placement, use of flags and/or different colors of clothing) or
- (ii) the transfer of crew, equipment or supplies, with a registered racing boat from the time the boat leaves its dock or mooring each day until the boat has finished racing for the day.

Notwithstanding the foregoing, (i) late arriving crew, food and drink may be transferred to a racing boat prior to the first race of the day, and (ii) crew may be transferred in the event of an unforeseen personal emergency. Infringements of this rule will result in a penalty to the boat associated with the support boat. Such penalty may be either penalties or disqualification at the discretion of the protest committee or jury.